

SIGRA OPTRONIC PTY LTD

Safety Light Curtains

PRODUCT DIGEST

Sigra Optronic Pty Ltd
Unit 1 / 2 Heald Road Ingleburn NSW 2565
PO Box 5240 Minto Business Centre MINTO NSW 2566
Phone 61 2 9829 5877 • Fax 61 2 9829 4855
ABN 26 092 011 320

CONTENTS

1	WHAT IS A LIGHT CURTAIN ?.....	1-1	2.6	SET UP AND ALIGNMENT	
1.1	CONTROLLERS	1-2	PROCEDURE:		2-5
1.2	INTERFACING WITH MACHINERY	1-3	2.6.1	DANGEROUS REFLECTIONS.	2-5
2	OPERATION MANUAL	2-1	2.6.2	RESET TERMINALS.	2-5
2.1	INTRODUCTION:	2-2	2.6.3	GREEN ALIGNMENT INDICATORS.	2-5
2.1.1	PRINCIPLE OF OPERATION.	2-2	2.6.4	RED ALIGNMENT INDICATORS.	2-5
2.2	SAFETY:	2-2	2.6.5	MULTIPLE CURTAIN SYSTEMS.	2-5
2.2.1	STANDARDS.....	2-2	2.6.6	MIRRORS	2-6
2.2.2	INSTALLER	2-2	2.7	TESTING PROCEDURE:	2-6
2.2.3	PERIODIC CHECKS	2-2	2.7.1	TEST PIECE	2-6
2.2.4	DETAILED INSPECTION.	Error!	2.7.2	FALSE CURTAINS.	2-6
	Bookmark not defined.		2.8	CONNECTION TO MACHINE	
2.2.5	ACCESS TO ADJUSTMENTS.	2-3	CONTROL.....		2-7
2.2.6	COVERS AND DOORS.....	2-3	2.8.1	SAFE INSTALLATION.....	2-7
2.3	OPERATING MODE:.....	2-3	2.8.2	CHECK OPERATION.....	2-7
2.3.1	GUARD ONLY.	2-3	2.8.3	OUTPUT POLARITY.	2-7
2.3.2	RESET FUNCTION.	2-3	2.8.4	INDUCTIVE FLYBACK.....	2-7
2.3.3	MUTING.....	2-3	2.8.5	SINGLE LOOP CONTROL.....	2-7
2.4	SYSTEM MOUNTING PROCEDURE	2-3	2.8.6	MUTE CONNECTION.....	2-7
			2.8.7	STOPPING PERFORMANCE	
2.4.1	STANDARDS.....	2-3	MONITORING		2-7
2.4.2	TRANSCEIVER POSITIONING.	2-3	2.9	DRAWINGS.....	2-8
2.4.3	TRANSCEIVER MOUNTING.	2-3	2.9.1	CLCBA100/101/102/103 Controller	
2.4.4	CONTROLLER MOUNTING.....	2-3	Dimensions		2-8
2.5	ELECTRICAL CONNECTION OF		2.9.2	CL300 TO 1800 TRANSCEIVER	
	SYSTEM COMPONENTS	2-3	DIMENSIONS.....		2-9
2.5.1	SAFETY.....	2-4	2.9.3	CL300MIR TO 1200MIR MIRROR	
2.5.2	CABLE TYPE	2-4	DIMENSIONS.....		2-10
2.5.3	SCREENING.	2-4	2.9.4	TRANSCEIVER WIRING	2-10
2.5.4	LOOSE WIRING.	2-4	2.9.5	CLCBA CONTROLLER WIRING... ..	2-12
2.5.5	COLOUR CODING.	2-4	2.9.6	SEPERATION DISTANCE.....	2-13
2.5.6	PLUG ASSEMBLY.....	2-4			
2.5.7	CONTROLLER TERMINATIONS.....	2-4			
2.5.8	LABELLING	2-4			

SIGRA LIGHT CURTAINS

2.10 TROUBLESHOOTING.....2-14

 2.10.1 GUARDS WON'T ALIGN (RED LIGHTS ON).....2-14

 2.10.2 GUARDS TRIP FOR NO APPARENT REASON.....2-15

2.11 SPECIFICATIONS.....2-16

2.12 STATEMENT OF COMPLIANCE ..2-18

3 ORDERING INFORMATION.....3-1

 3.1 PART NUMBERS3-2

 3.2 APPLICATION SHEET3-3

 3.3 TERMS & CONDITIONS OF SALE ..3-4

4 STANDARDS.....4-1

 4.1 AS4024.2(INT.) 1992.....4-1

 4.2 AS4024.1 19964-1

 4.3 AS4024.2 1998. INSTALLATION AND COMMISSIONING REQUIREMENTS FOR ELECTRO-SENSITIVE SYSTEMS- OPTOELECTRONIC DEVICES.....4-1

 4.4 AS4024.3 1998.....4-1

 4.5 AS4024 PARTS 4 & 54-1

 4.6 BS6491 PARTS 1 AND 2.....4-1

 4.7 IEC61496 PARTS 1 AND 2.....4-1

 4.8 EN501004-1

 4.9 SIGRA APPROVALS4-1

5 MACHINE INTERFACING.....5-1

 5.1 ANTI-REPEAT.....5-1

 5.2 VALVE MONITORING.....5-1

 5.3 MUTING.....5-1

 5.4 APPLICATIONS IDEAS.....5-1

 5.5 RISK ANALYSIS.....5-1

6 ACCESSORIES.....6-1

 6.1 MIRRORS6-1

 6.2 CHEMICAL SEALING KITS.....6-1

 6.3 HAZARDOUS AREAS.....6-1

 6.4 POWER SUPPLIES6-1

 6.5 CABLES6-1

7 INDEX.....7-1

THE SIGRA CL SYSTEM

1 WHAT IS A LIGHT CURTAIN?

Very simply, a Safety Light Curtain is a device used to **protect persons from dangerous machinery**. A Safety Light Curtain is made up of two electronic sensor bars (**Transceivers**), which send and receive invisible infra-red beams between each other. These transceivers are connected, as per **Figure A**, to a **Controller**, which receives electronic signals from the transceivers and from these signals decides whether or not the area between the transceivers is clear or obstructed.

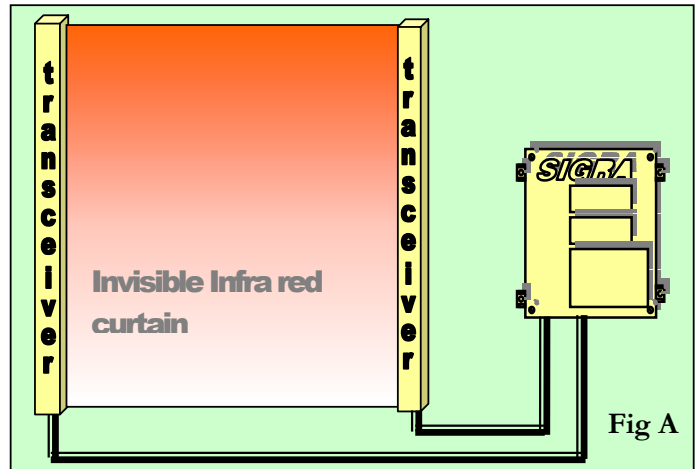

Fig A

The **Safety Light Curtain** is placed between a machine operator and a dangerous machine as per **Figure B**, so that if the operator puts any part of their body into the machine, then some of the infra-red beams between the Transceivers will have been obstructed. The Controller will then send a stop signal to the machine, before the operator can be injured.

SIGRA Transceivers are available in heights from 300mm to 1800mm, and can operate at ranges of up to 50 metres apart, however, ranges over 6 metres need to specified.

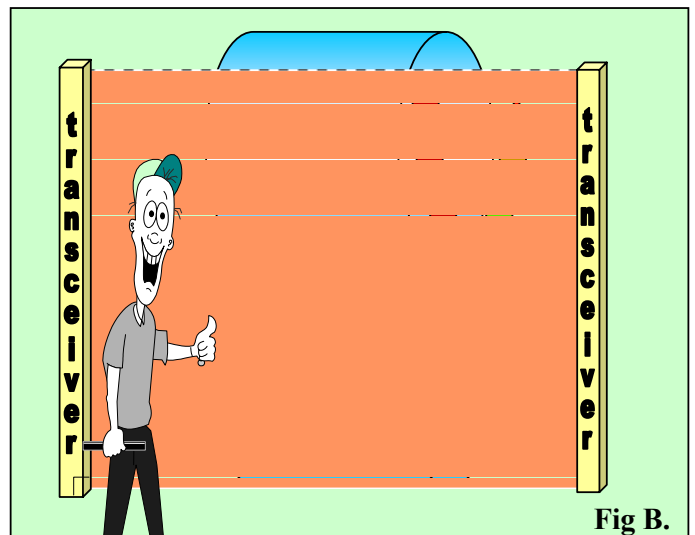
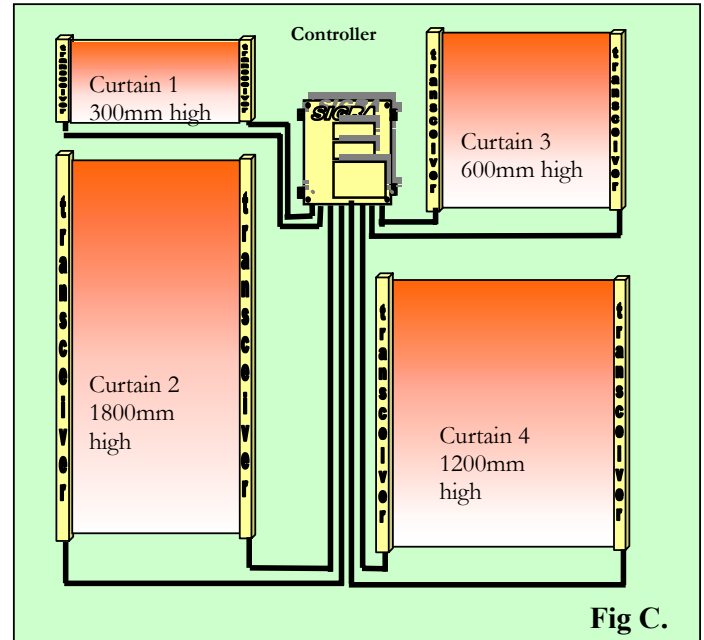

Fig B.

1.1 CONTROLLERS

SIGRA Controllers can operate up to four curtains (see **fig C&D**) with any mixture of sizes and ranges. This can be a useful feature if you wish to guard four sides of a machine.

Note, although 4 Curtains are controlled, the Controller output will switch to stop the machine regardless of which light curtain is obstructed.



1.1.1 CONTROLLER FUNCTIONS.

The Light Curtain Controller is connected to each transceiver using **4 core** screened cable. The Controller determines from the signals from each transceiver, if the curtain area between the Transceivers is clear and provides outputs, which are used to stop the dangerous motion of the machine if the curtains are obstructed. This can be done by using the outputs to close or open valves to brakes or cylinders on the machine to stop the dangerous motion.

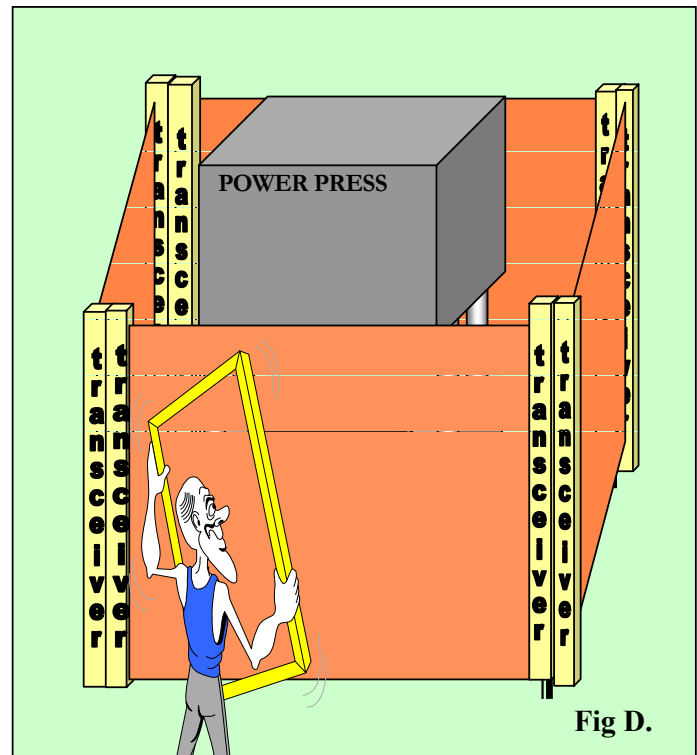

1.2 INTERFACING WITH MACHINERY

The **Light Curtain Reset.** inputs have several uses. Resets can monitor the correct operation of the valves or other devices which the Light Curtain Outputs are controlling. They can be used with a push-button as a manual reset once the light curtain has been obstructed. They can also provide a very useful “anti-repeat” function, which does not allow the machine to re-start on it’s own once the curtain is unobstructed.

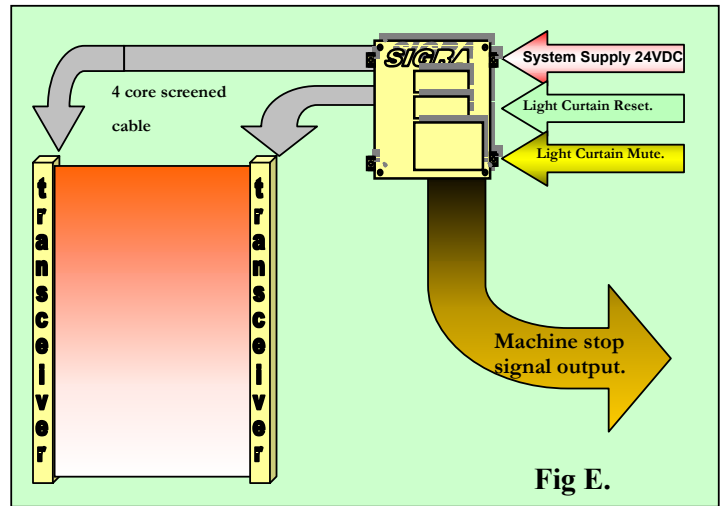

The **Light Curtain Mute.** inputs effectively bypass the Safety Light Curtain. This can be useful for machine set up. These inputs can also be automatically activated by the machine during safe portions of a cycle, such as the opening stroke of the power press as shown in **Figure D**. This would allow the operator to step into the guarded area to remove the work-piece whilst the press was opening. The Mute inputs can also be used to make the Light Curtain UNIDIRECTIONAL, in other words product may be allowed to exit through the Light Curtain but nothing may enter through the Light Curtain.

Corner mirrors can be used to bounce the Light Curtain beams around corners. This would allow you, for example, to guard the application shown in the above **Figure D** with two corner mirrors and four less transceivers. Note, mirrors should not be used over distances totaling more than 12 metres. The main disadvantage of using mirrors is that they can be very difficult to align. Any mountings for mirrors should be very strong and robust. Mirrors are not recommended for use in high traffic areas as they will need constant re-alignment.

Other accessories include Chemical wash-down enclosures, Power Supplies, Dust Ignition Proof Enclosures, Pre-wired Cable assemblies and cables. See **Section 7**

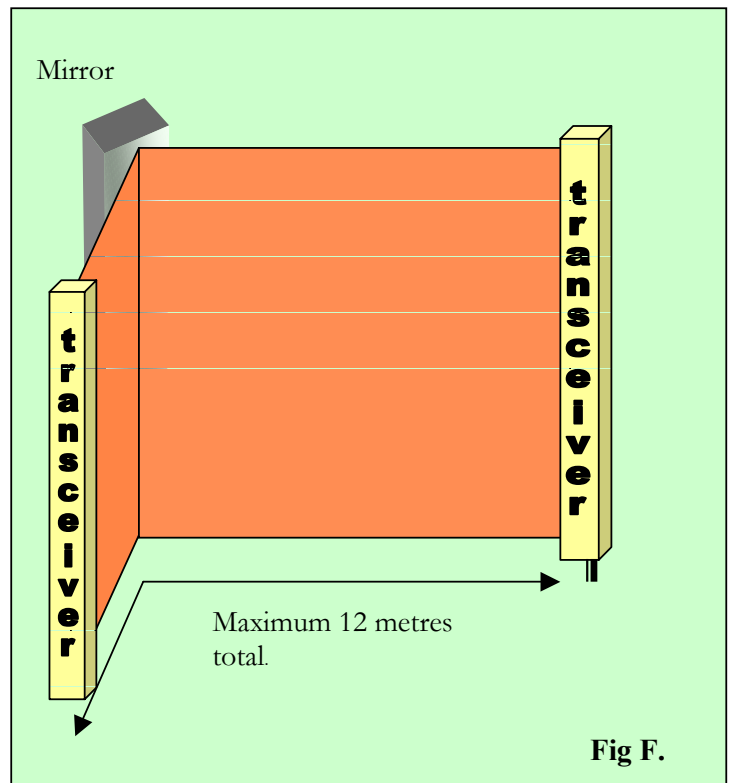

SIGRA LIGHT CURTAINS

**2 OPERATION
MANUAL**

Section

2

**CLA
4 WIRE
SYSTEMS**

2.1 INTRODUCTION:

The SIGRA CLA system of Photoelectric Light guards is a further refinement of this unique and innovative concept in light curtain technology, suitable for guarding a variety of powered machines which can be stopped at any portion of a dangerous stroke, with an electrical signal. Two identical Transceiver Bars are used to establish an invisible "curtain" of light between them. A Controller which drives the Transceivers, processes the digital signals from the transceivers and other interlock switches/devices, and provides electrical outputs to the machine corresponding to "CURTAIN CLEAR" or "CURTAIN OBSTRUCTED". The CLA System Controller can run up to a maximum of 4 complete curtains.

2.1.1 PRINCIPLE OF OPERATION.

The system essentially operates on the proven through-beam, transmit/receive principle. However, as the transceiver bars are identical and each performs both transmit and receive functions, they generate the unique, invisible Safety Net pattern as shown in FIG.1. The area of a curtain is defined by the transceiver lens.



WARNING: SYSTEMS INSTALLED BY UNQUALIFIED PERSONS CAN BE UNSAFE. THE INSTALLER SHOULD BE FAMILIAR WITH LOCAL REGULATIONS, AND MUST READ THIS MANUAL THOROUGHLY PRIOR TO ATTEMPTING INSTALLATION.

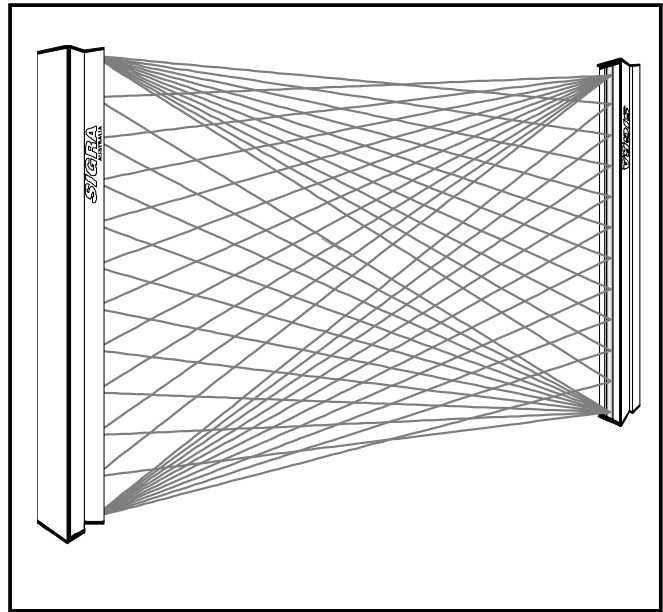

FIG 1. DETECTION PATTERN

2.2 SAFETY:

2.2.1 STANDARDS

The CLA 2 System was designed along guide-lines as defined by Australian and International standards.

2.2.2 INSTALLER.

The CLA System must be installed and commissioned by a competent installer and in a manner conforming to local Occupational Health and Safety regulations. In some states it is mandatory to advise the regulatory authorities of the installation.

2.2.3 PERIODIC CHECKS.

It is recommended that periodic checking of the Light Curtain be done as part of the normal operating procedure of the machine. For example, at the start of a shift, the operator would insert the provided test piece(s) at various positions within the guarded area to verify correct operation of the guard, machine, and interface circuitry.

2.2.4 DETAILED INSPECTION.

It is also strongly advised that regular inspections be carried out, by a competent person, of the safety systems with particular attention to mechanical wear of valves, hydraulics, and relays at intervals not exceeding six months.

SIGRA LIGHT CURTAINS

2.2.5 ACCESS TO ADJUSTMENTS.

It is recommended that any keys or special tools required for access to system adjustment or set-up be held by responsible, authorized personnel only.

2.2.6 COVERS AND DOORS.

No covers or doors are to be left opened whilst the system is in normal operation. Failure to comply with this requirement voids safety compliance.

2.3 OPERATING MODE:

2.3.1 GUARD ONLY.

The CLA System standard mode of operation is Guard Only, i.e.; any interruption of the curtain causes the output relays to de-energize and open the circuit to the MACHINE PRIMARY CONTROL ELEMENTS.

2.3.2 RESET FUNCTION.

The CLA controller provides facility for automatic or manual reset via external contacts. This reset facility can also be used for monitoring of external devices such as valve limit switches, stopping performance monitors etc.

2.3.3 MUTING.

The CLA controller provides facility for muting or by-pass of the light curtain. This can be a useful feature for automated processes where access through the curtain is required during the safe portion of a machine cycle. The mute feature can also be used to create pulse type circuits for brake presses by using timers.

2.4 SYSTEM MOUNTING PROCEDURE

2.4.1 STANDARDS

Prior to mounting transceivers, the machine to be guarded should be assessed in accordance to AS4024.2, Sect 2.

2.4.2 TRANSCEIVER POSITIONING.



THE MINIMUM SEPERATION DISTANCE FROM THE LIGHT CURTAIN TO THE DANGEROUS PART OF THE MACHINE MUST BE CALCULATED.

Drawing 2.9.6 is a guide to separation distances of Sigra Light Curtains compared to total machine stopping time.

Position transceiver allowing at least 20mm clearance from the end of the mounting bracket to any obstruction for easy access. Mark the mounting holes using Transceiver with brackets fitted as a template. **Note: Transceivers must be parallel and at the same height.**

2.4.3 TRANSCEIVER MOUNTING.

Mount brackets and Transceiver, leaving locking screws loose to allow alignment.

2.4.4 CONTROLLER MOUNTING.

Mount controller cabinet. Be sure to retain the IP54 rating of the cabinet. Allow sufficient clearance at the front of the cabinet to allow removal of the cabinet cover and at the top and bottom to allow fitting of glands and cables.

2.5 ELECTRICAL CONNECTION OF SYSTEM COMPONENTS

The components of the Safety Light Curtain System should be mounted, wired and tested as a separate system before any connection is made to the machine control.

See **Drawing 2.9.4** (Transceiver wiring) for connecting System components.

See **Section 2.8** and **Drawing 2.9.5** (Controller wiring) for connection to machine control.

2.5.1 SAFETY



SYSTEMS INSTALLED BY UNQUALIFIED PERSONS CAN BE UNSAFE. THE INSTALLER SHOULD BE FAMILIAR WITH THE REQUIREMENTS OF LOCAL STATUTORY AUTHORITIES AND THE MACHINE TO WHICH THE SYSTEM IS BEING FITTED. READ THIS MANUAL THOROUGHLY BEFORE INSTALLATION

2.5.2 CABLE TYPE.

For any connections to Transceivers, Mute or Reset, always use screened cables with outside diameter 5 to 7mm. Use 4 core cable for transceivers, mute and reset.

2.5.3 SCREENING.

Cable screens should only be grounded at supply 0V (controller terminals 5, 13, 21 or 29) **DO NOT EARTH.**

2.5.4 LOOSE WIRING.

Note: all loose unscreened wiring and especially mains or switched outputs should be kept away from the controller board and signal wiring to transceivers. Failure to do so may result in false tripping.

2.5.5 COLOUR CODING.

Each transceiver requires four wires from the controller, so it is strongly recommended that suggested wire colours as per **Drawing 9.3.4** be followed to ease installation, and troubleshooting.

2.5.6 PLUG ASSEMBLY.

Individual wiring of the transceivers is achieved by soldering the wires onto the loose pins provided and fitting them into the pin carrier using the insertion tool provided. Pins can easily be held for soldering by insertion into holes drilled in a block of wood. Care should be taken to ensure that solder is only present

inside the bucket of the pin, as any solder on the outside of the pin will prevent withdrawal of the insertion tool. See **FIG 2**

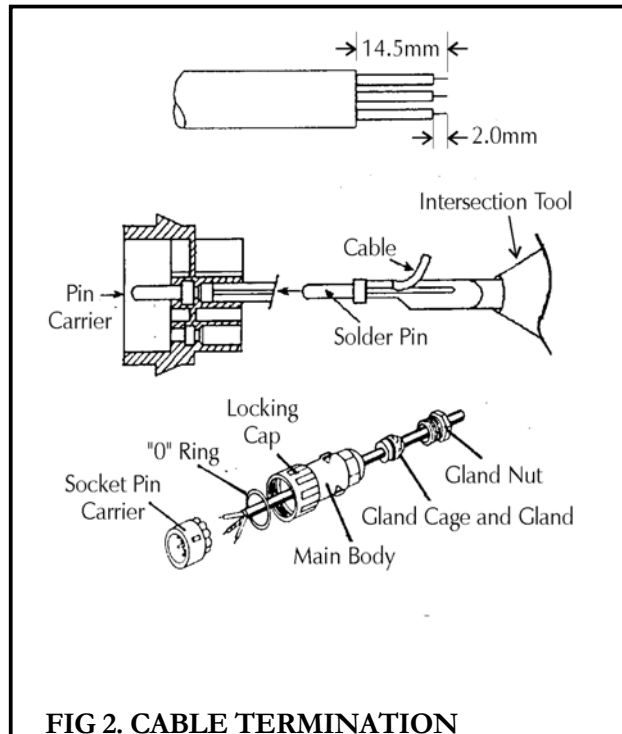

FIG 2. CABLE TERMINATION

NOTE:

Pins must be fully inserted into the pin carrier. Pins will be flush with the front surface of the pin carrier. A definite “click” can be felt

2.5.7 CONTROLLER TERMINATIONS

When running cable from transceivers into controller it is best to leave enough slack inside controller to enable connection to ANY of the terminals

NOTE: Shield should not be stripped back further than 50mm from terminal block, otherwise inadequate shielding and intermittent trips may result.

2.5.8 LABELLING

Cable markings are essential, especially in multi curtain systems. Label both ends of Transceiver cables and all Transceiver cases with the Transceiver numbers supplied (A1, B1, A2, B2.....etc).

2.6 SET UP AND ALIGNMENT PROCEDURE:



DO NOT PLUG OR UNPLUG ANYTHING WHILE POWER IS APPLIED TO SYSTEM.

2.6.1 DANGEROUS REFLECTIONS.

Care should be taken to ensure that a curtain is established between the Transceivers and not a "false curtain" via reflection from a third object such as a mirror. See **Section 2.7.2**. Where mirrors are intended to be used, the installer should always obtain technical advice from Sigra to ensure safe installation of equipment.

2.6.2 RESET TERMINALS.

For testing purposes, bridge reset terminals 40-41 and 42-43.

2.6.3 GREEN ALIGNMENT INDICATORS.

A green status light is provided on each transceiver, these correspond to the signal strength of the receivers at each end of the transceiver. The green status lights increase in brightness with alignment.

2.6.4 RED ALIGNMENT INDICATORS.

A red alignment indicator is provided on each transceiver. This will extinguish when both receivers on the transceiver are receiving all signals from the counterpart transceiver.

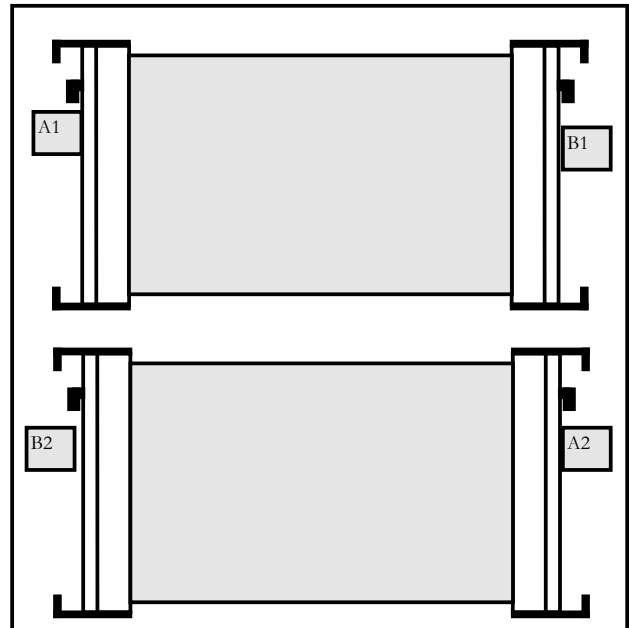

FIG.3 TWO CURTAIN SYSTEMS.

2.6.5 MULTIPLE CURTAIN SYSTEMS.



CROSS TALK BETWEEN INDIVIDUAL CURTAINS IN A SYSTEM CAN CAUSE "HOLES" IN ONE OR MORE CURTAINS.

Refer to **Fig 3** for connection details to prevent cross talk when using 2 or more curtains. When Transceivers from second, third or fourth curtains are in close proximity or line of sight, always ensure that:

-“A” transceivers can only see corresponding “B” Transceivers.

-“B” Transceivers can only see corresponding “A” Transceivers.

“A” Transceivers looking at other “A” Transceivers or “B” Transceivers looking at other “B” Transceivers do not cause cross talk.

Align A1 to B1 so that the green status leds on both transceivers are brightest. The red status indicators should extinguish on these Transceivers.

Align A2 to B2 so that the green status leds on both transceivers are brightest, at which time red status leds on these transceivers should extinguish. Continue the procedure for every curtain in the system. Once the Reset terminals are closed, the output relays will close.

2.6.6 MIRRORS

A curtain can be established between two Transceiver Bars via a mirror. Mirrors to suit different lengths of Transceiver Bars are available from Sigra. Mirrors will attenuate the range of the curtain and care must be taken to ensure "false" curtains are not established. See FIG 4. The angle between arms of the reflected curtain must be greater than 90 deg. unless advice is sought from Sigra. This minimum angle prevents objects other than the mirror reflecting the curtain and creating an unsafe condition.

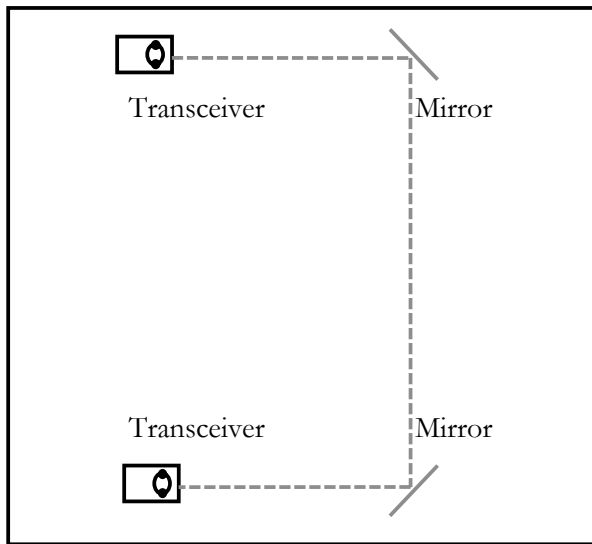

FIG 4. MIRRORS

2.7 TESTING PROCEDURE:

2.7.1 TEST PIECE

For each curtain in the system: insert the correct test piece corresponding to the Transceiver resolution. See Section 2.11. The output relays must remain in the off position whilst ever the correct test piece is anywhere in the curtain area. The curtain area is formed between the endcaps of each transceiver in the curtain.

2.7.2 FALSE CURTAINS.

When setting up and testing the system, be sure that a "false" curtain has not been established either by Misalignment of the Transceiver Bars or by close positioning to a reflective object. This third object may possibly be a mirror in the case of an intended reflection. Any object can reflect Infrared light under the right conditions and the protected area of the curtain may not be in the intended location or may have dead zones (holes) created within the curtain. See Fig 5.

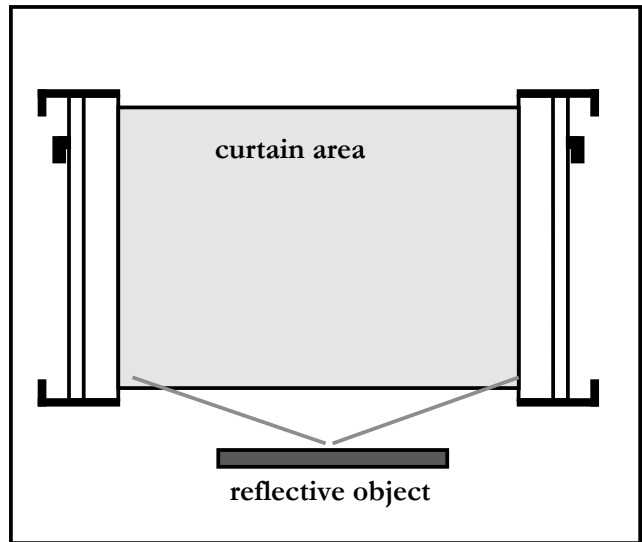

FIG 5. FALSE CURTAINS

2.8 CONNECTION TO MACHINE CONTROL



SYSTEMS INSTALLED BY UNQUALIFIED PERSONS CAN BE UNSAFE. THE INSTALLER SHOULD BE FAMILIAR WITH THE REQUIREMENTS OF LOCAL STATUTORY AUTHORITIES AND THE MACHINE TO WHICH THE SYSTEM IS BEING FITTED. READ THIS MANUAL THOROUGHLY BEFORE INSTALLATION

2.8.1 SAFE INSTALLATION.

Some local Authorities require the use of two MACHINE PRIMARY CONTROL ELEMENTS, (MPCEs), each driven by separate relays (FINAL SWITCHING DEVICES, "FSD"s). The MPCEs must also be monitored for correct operation, and the overall stopping performance of the machine may need to be monitored. It is not possible to anticipate every type of installation, therefore it is essential that the installer have a good knowledge of local regulations and to interface the CLA system to the machine in conformance to those regulations.

2.8.2 CHECK OPERATION

Once the installer is satisfied that the guard is functioning correctly, connection of the machine interface can be carried out. See **Drawing 2.9.5.**

2.8.3 OUTPUT POLARITY.

Two output relays are provided RLY1. and RLY2. Note that the connections for these relays are marked + and -. **REGARDLESS OF THE VOLTAGE BEING SWITCHED, ENSURE THAT THE MOST POSITIVE POLARITY IS ON THE + TERMINAL. OR WHEN SWITCHING A.C. THE SIDE OF THE CIRCUIT THAT STAYS LIVE IS CONNECTED TO THE + TERMINAL.**

2.8.4 INDUCTIVE FLYBACK.

When switching inductive loads e.g.; contactors, solenoids etc.. arc suppressors will be required across the inductive load **NOT ACROSS THE RELAY CONTACTS (refer FIG.5).** For inductive loads which draw more than 10VA, slave relays are recommended.

2.8.5 SINGLE LOOP CONTROL.

Where local regulations do not require two separate MACHINE PRIMARY CONTROL ELEMENTS and your machine control does not have facility for two separate inputs, you must provide a series link from RLY1-(MINUS) TO RLY2+(PLUS) and can then consider this arrangement as a single relay.

2.8.6 MUTE CONNECTION.

The MUTE function is available by shorting terminals 44-45 and 46-47 e.g.; via spare contacts on limit switches etc. **BS6491** requires mute selection to be by key operated switch which is to be supplied by the installer.

2.8.7 STOPPING PERFORMANCE MONITORING

May be required on certain applications, see **Section 2.8.1.**

2.9 DRAWINGS

2.9.1 CLCBA100/101/102/103 Controller Dimensions

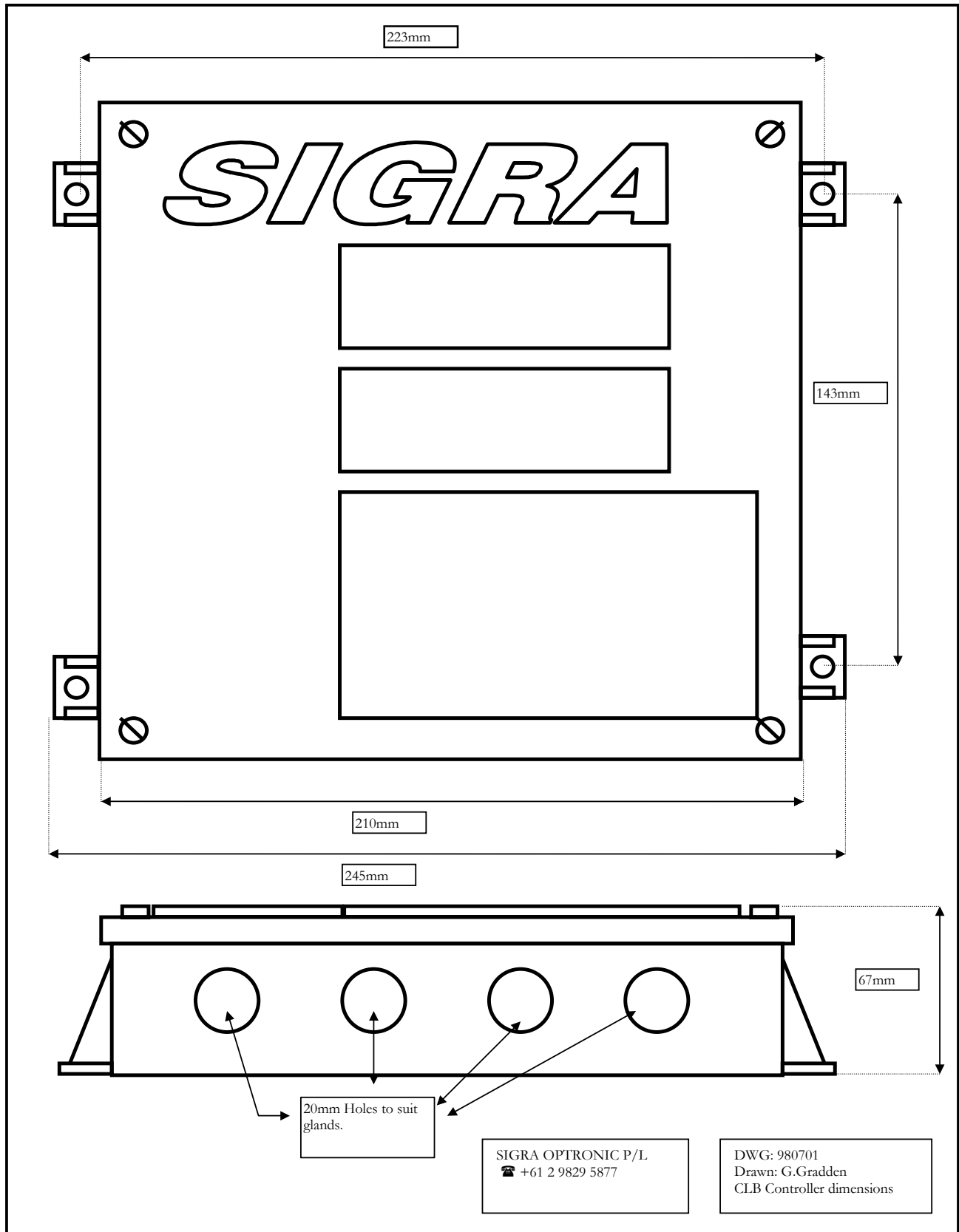

SIGRA LIGHT CURTAINS

2.9.2 CL300 TO 1800 TRANSCEIVER DIMENSIONS

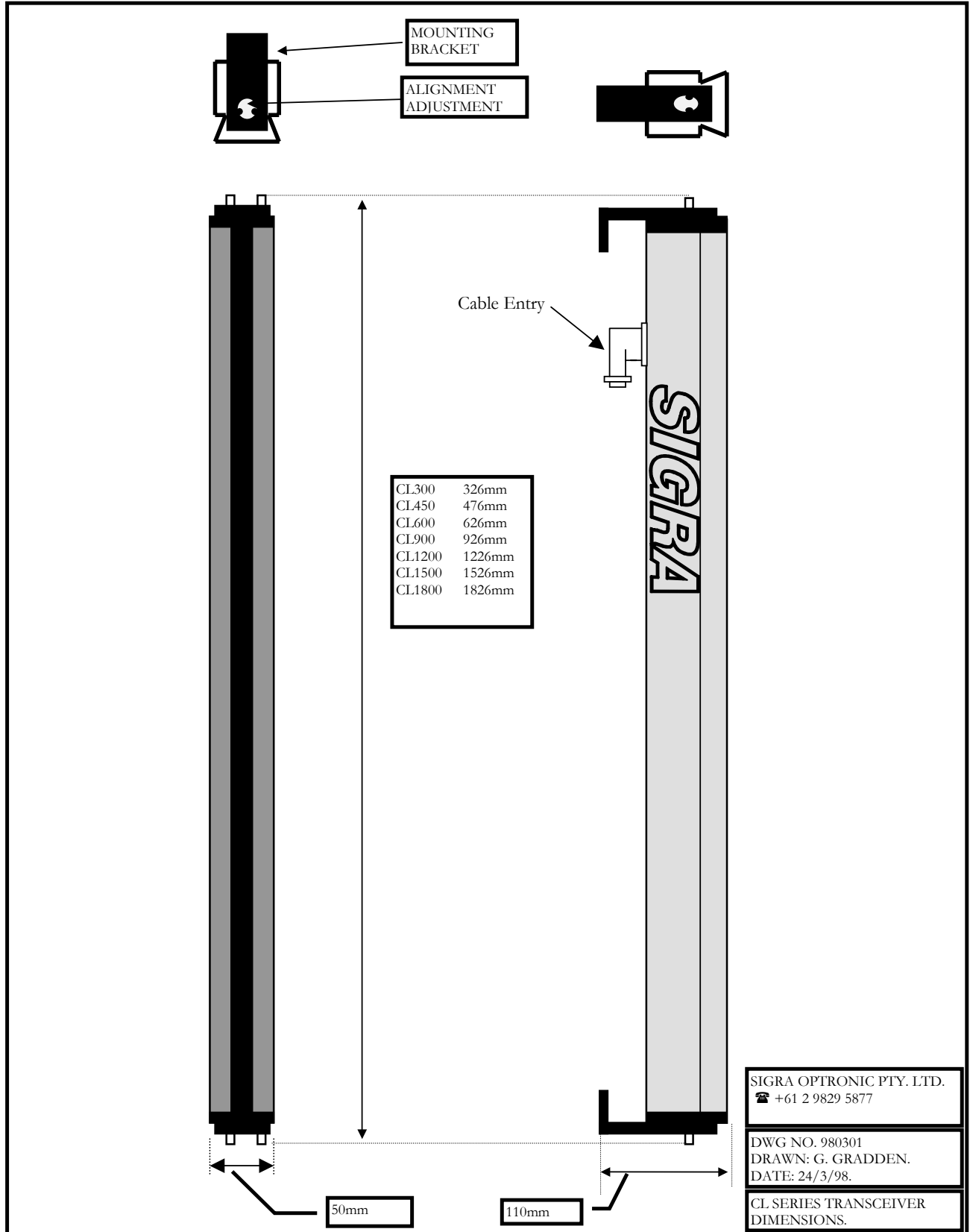

SIGRA LIGHT CURTAINS

2.9.3 CL300MIR TO 1200MIR MIRROR DIMENSIONS

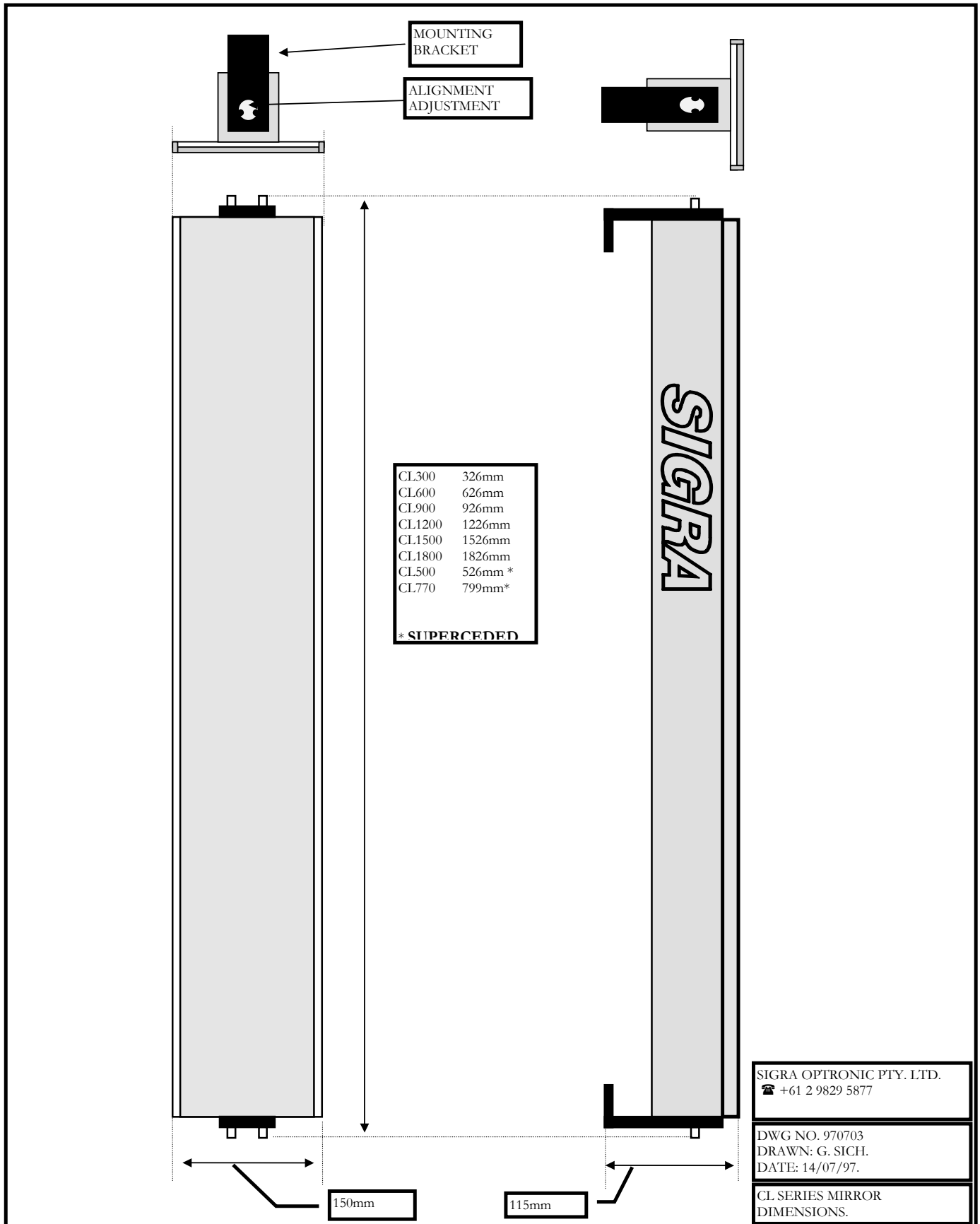

2.10 TRANSCEIVER WIRING.

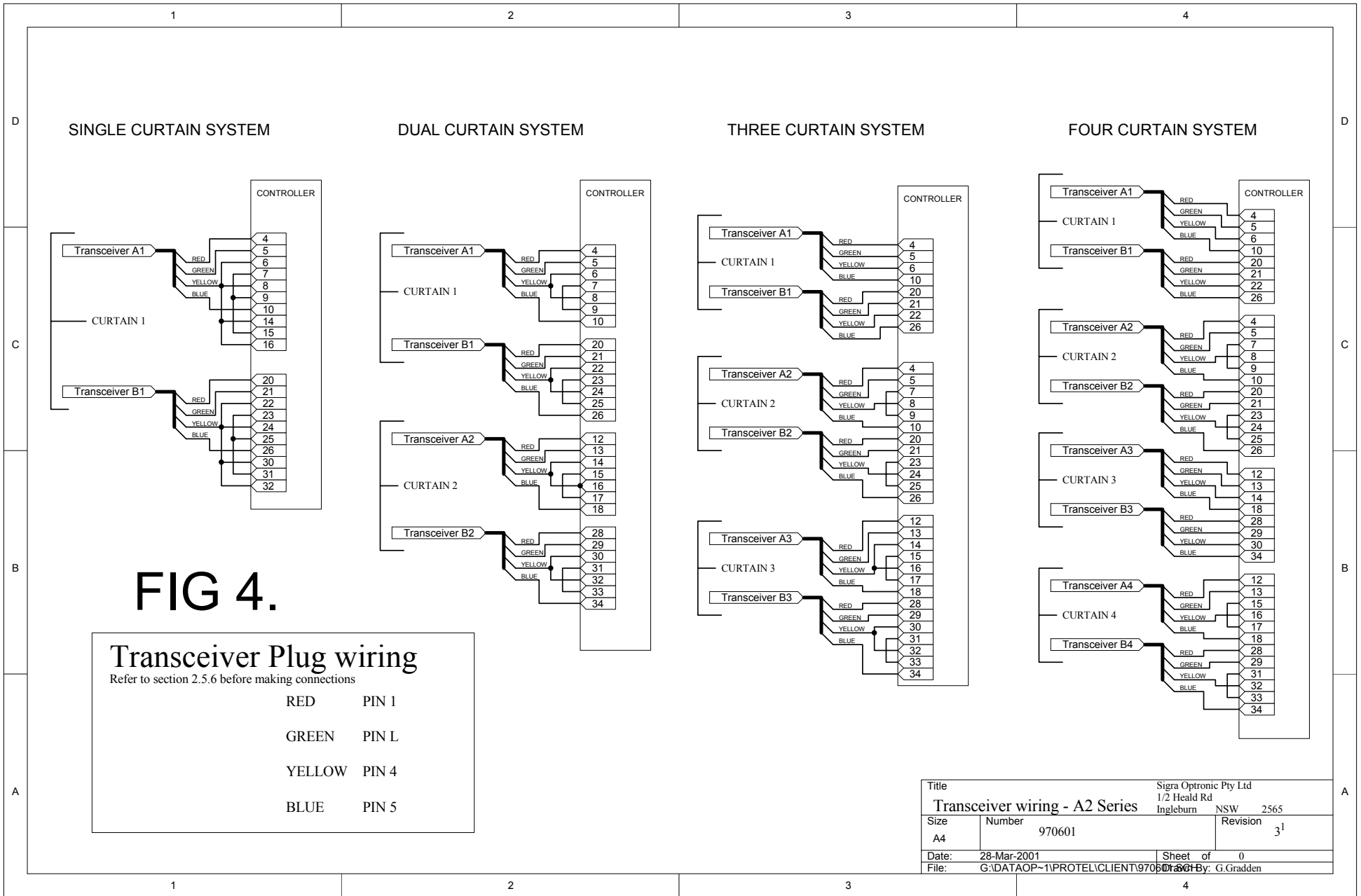

2.10.1 CLA CONTROLLER WIRING

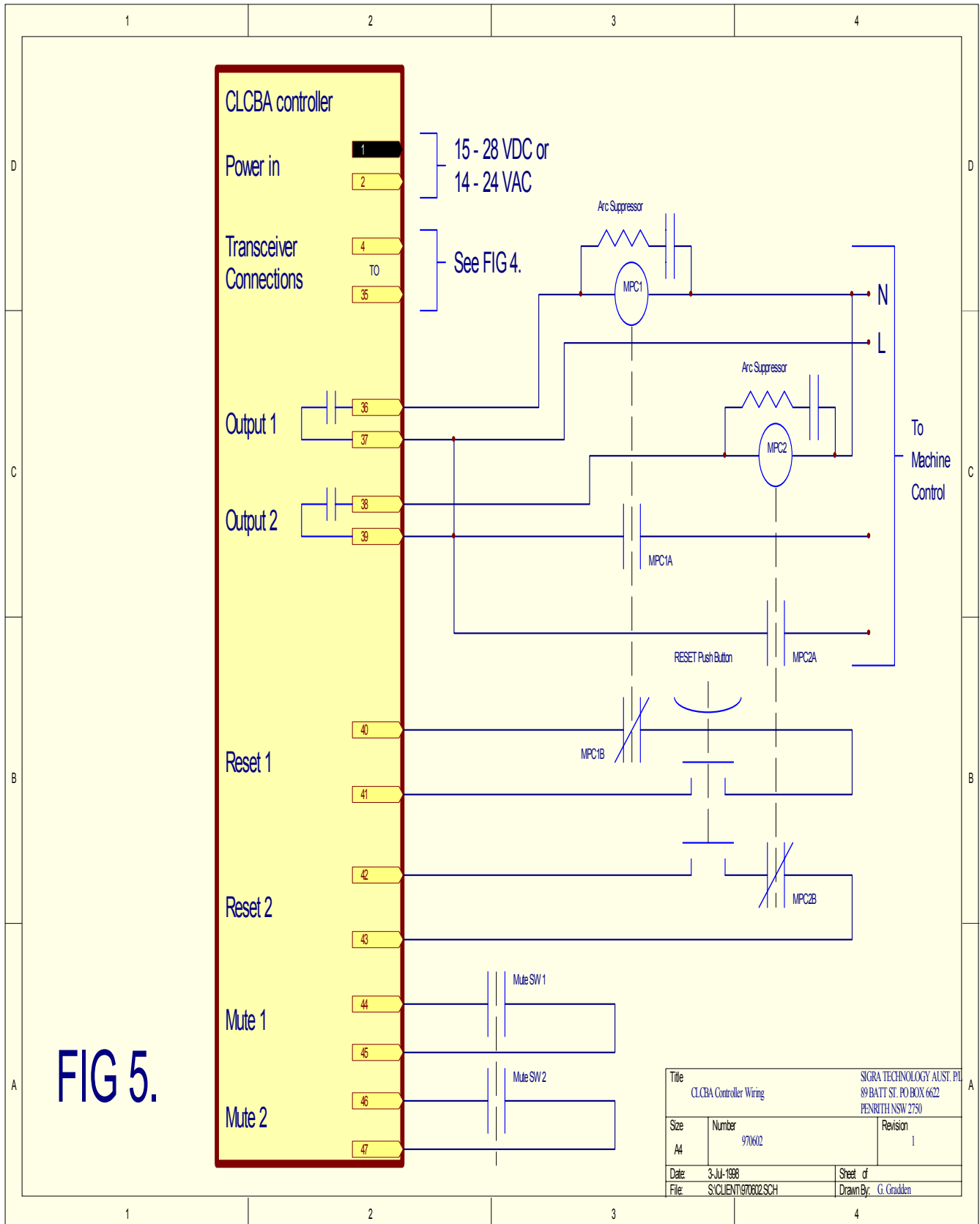
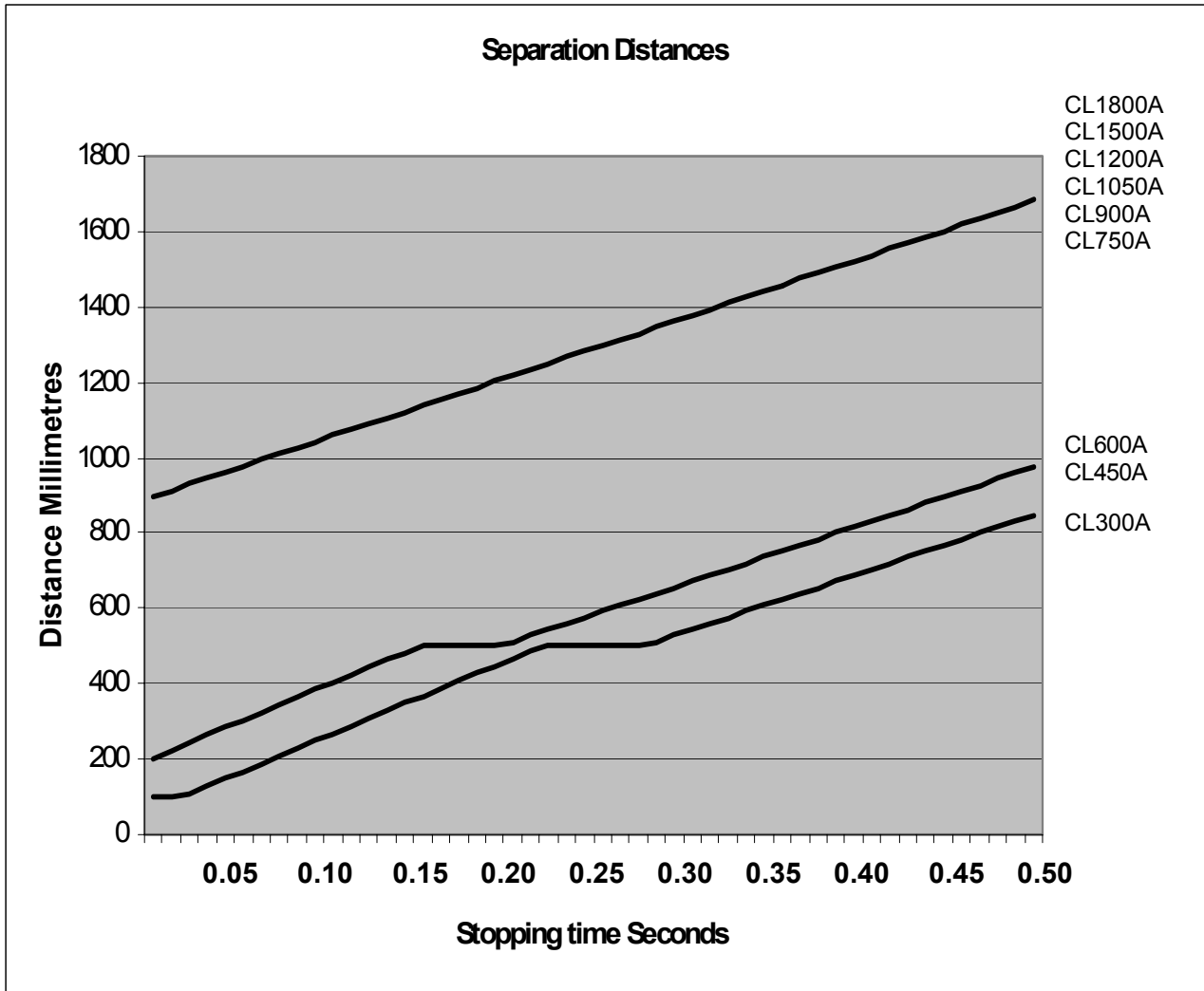

FIG 5.

Title		SIGRA TECHNOLOGY AUSTRALIA PTY LTD 89 BATT ST. PO BOX 6632 PENRITH NSW 2750	
Size	Number	Revision	
A4	970602	1	
Date	3-JUL-1998	Sheet	of
File	S:\CLIENT\970602.SCH	Drawn By:	G. Cradden

SIGRA LIGHT CURTAINS
2.10.2 SEPERATION DISTANCE



**2.11 TROUBLESHOOTING
CLA 2 SERIES.**

**2.11.1 GUARDS WON'T ALIGN
(RED LIGHTS ON)**

2.11.1.1

Sections 5 and 6 of the manual should be read thoroughly before attempting to fault find. All electrical connections should be checked before proceeding.

2.11.1.2

Are transceivers within the correct lens to lens range specified on serial number label?

2.11.1.3

Are reset links fitted as per section 6.2

2.11.1.4

Check transceiver alignment as per section 6.3, 6.4 & 6.5.

2.11.1.5

Do green status on each bar vary in brightness when aligned and misaligned? (If the green status indicator does not respond, replace transceiver.

2.11.1.6

Are transceivers parallel and at the same height? Both horizontal and vertical alignment is required. (Do not assume the floor is level).

2.11.1.7

Is 18-24VDC present between terminals 5 and 4? (If not, check fuses and verify that the correct mains voltage is being supplied to the system.)

2.11.1.8

Unplug all transceivers at the back of the bar. At the controller, using terminal 3 as 0V reference, check terminals 9 (Scan A) and 25 (Scan B) for 6VDC, and terminals 10 (Clock A) and 26 (Clock B) for 1VDC.

2.11.1.9

Replace controller if these voltages are not correct.

2.11.1.10

Plug transceivers back in. Using terminal 5 as 0V reference, and Fig 4 for cable identification, look at the voltages at controller terminals for individual transceivers:

Terminal	DC voltage
4.	15-28
5.	0
6.	6-9
7.	5.8-6.2
8.	6-9
9.	5.8-6.2
10.	0.7-1.1
11.	N/A.
12.	15-28
13.	0
14.	6-9
15.	5.8-6.2
16.	6-9
17.	5.8-6.2
18.	0.7-1.1
19.	N/A.
20.	15-28
21.	0
22.	6-9
23.	5.8-6.2
24.	6-9
25.	5.8-6.2
26.	0.7-1.1
27.	N/A.
28.	15-28
29.	0
30.	6-9
31.	5.8-6.2
32.	6-9
33.	5.8-6.2
34.	0.7-1.1
35.	N/A.

2.11.1.11

Check wiring to transceiver (including plug assembly) if voltages not correct. If wiring OK, replace transceiver and retest.

SIGRA LIGHT CURTAINS

2.11.1.12

If at this stage the fault has not been found, contact Sigra for technical advice before proceeding.

2.11.2 GUARDS TRIP FOR NO APPARENT REASON.

2.11.2.1

Check as per 10.1.1, 10.1.2, 10.1.4 & 10.1.6

2.11.2.2

Controller board should be mounted inside Sigra control box as it provides shielding.

2.11.2.3

Move all loose wiring away from controller PCB and unshielded sections of transceiver and reset wiring.

2.11.2.4

Ensure shielded cable has been used for connections to transceivers and reset terminals. Shields are connected at controller only to 0VDC and not earth. Ensure also that shielding is not stripped back further than recommended in 5.4

2.11.2.5

Transceivers must be mounted using the insulation kits. With the transceiver unplugged and using an ohm-meter (not a megger), check that there is no circuit from each transceiver bracket screw to earth.

2.11.2.6

An earth reference connected to terminal 3 on earlier systems is not required and can create earth loops. Disconnect it.

2.11.2.7

Ensure the transceivers are mounted securely so that they cannot be misaligned through bumping or vibration.

2.11.2.8

Check the possibility of any optical crosstalk from other light curtains or photo-electric devices.

2.11.2.9

Contact Sigra if fault persists.

2.12 SPECIFICATIONS.

Power requirements 15-26 VDC or 14-18VAC ; Controller 500mA, Transceiver 70mA.

Outputs 2 x 2Amp Fused Normally Open Contacts.

Size and Detection Capability.

Curtain Heights;	Resolution.
300mm	20mm
450mm	35mm
600mm	35mm
900mm	50mm
1200mm	70mm
1500mm	90mm
1800mm	110mm

Maximum Operating Range 50 metres

Response Time; Less than 20mS.

Environmental Protection Transceivers I.P.65.
Controller I.P.54.

Ambient Temperature; 0 to 50° Centigrade.

The CLA system uses state of the art electronics and techniques. Advances in technology may change specifications from time to time.

Optional Specifications on request;

D.I.P. Dust Ignition Proof Housing.

S.K. Chemical Sealing Kits.

EXP Flame Proof Housing.

MIR Corner Mirrors.

2.13 STATEMENT OF COMPLIANCE

SIGRA **OPTRONIC** PTY LTD A.C.N. 092 011 320
P.O. BOX 5240 Minto Business Centre, MINTO N.S.W. 2566
PHONE: 61 (2) 9829 5877 FAX: 61 (2) 9829 4855

Statement of Compliance

The Sigra CL system of safety light curtains has been independently verified for compliance to AS4024.3-1998 and meets the criteria for a Category 4 safety control system, and Interlock Category 6.

Relevant documentation;

WorkCover Authority Test Report 9004 File No. 92/4239.

Standards Australia Document MDS:mds sf41 19th February 1998.

ADI ltd. Test Certificate 8757

George Sich
Product Manager.

3 ORDERING INFORMATION

Use part numbers from **Section 3.1**. Be sure to fill out the application sheet, **Section 3.2** with all relevant details. This application sheet is very important, as it will prevent the wrong equipment being ordered.

The Part Numbering has been chosen to be as simple as possible. For instance, the CL is abbreviated “CURTAIN, LIGHT”, PW ; “PRE-WIRE”, etc. When selecting transceivers, for example CL600A, the actual detection zone of the transceiver is 600mm. The physical size of the transceivers is slightly larger, and you can find these dimensions in **Drawing 2.9.2**

Note: As transceiver size increases, detection capability also gets larger, so don't assume that bigger is necessarily better. The smaller the transceiver, the closer it can usually be placed to the danger point of the machine you are trying to guard. Just how small you can go is usually determined by reaching over or under the curtain. If you need a large curtain very close to the danger point, consider using multiple curtains stacked above each other.

Are you aware that transceivers are supplied with **different operating ranges?** These are generally;

-Operating range less than 1metre,

-Operating range 1 to 2metres, or 2-6 metres, or 6-12 metres, or 12 to 20 metres and over 20 metres. So it is vitally important to fill in the application sheet.

-Standard transceivers have a very high immunity to weld flashes and strobes, however they cannot cope well in outdoor sunlight conditions, for this we have a high ambient light model, again all you need to do is tick the right box in the ordering sheet, and it is the same price.

Conditions of sale are in **Section 3.3**

SIGRA LIGHT CURTAINS
3.1 PART NUMBERS

Complete systems

Part No.	Description.	Res.	Standard Ranges
CL300ASYS	Curtain 300mm high	20mm	0.3-1.0m, 1-2m, 2-6m, 6-12m
CL450ASYS	Curtain 450mm high	32mm	0.5-1.0m, 1-2m, 2-6m, 6-12m
CL600ASYS	Curtain 600mm high	32mm	0.5-1.0m, 1-2m, 2-6m, 6-12m
CL900ASYS	Curtain 900mm high	50mm	1-2m, 2-6m, 6-12m, 10-20m
CL1200ASYS	Curtain 1200mm high	70mm	1.2-6m, 6-12m, 10-20m
CL1500ASYS	Curtain 1500mm high	90mm	2-6m, 6-12m, 10-20m
CL1800ASYS	Curtain 1800mm high	110mm	2-6m, 6-12m, 10-20m

Systems Are: two transceivers, a controller and all plugs and parts required to assemble a single curtain.

A Controller can operate up to 4 complete curtains, so individual controller and transceiver prices are listed below (Note: prices are for each transceiver, 2 transceivers are required to form an additional curtain).

Other Curtain Sizes and Ranges up to 50 metres are available on request.

Individual Transceivers and Controllers

CLCBA770	Controller for up to 4 curtains
CL300A	Transceiver 300mm High
CL450A	Transceiver 450mm High
CL600A	Transceiver 600mm High
CL900A	Transceiver 900mm High
CL1200A	Transceiver 1200mm High
CL1500A	Transceiver 1500mm High
CL1800A	Transceiver 1800mm High

Corner Mirrors

CL300MIR	300mm High
CL450MIR	450mm High
CL600MIR	600mm High
CL900MIR	900mm High
CL1200MIR	1200mm High
CL1500MIR	1500mm High
CL1800MIR	1800mm High

Cables and Accessories

CLAPLUG	Free Plug
PW05	Transceiver plug pre-wired. Add cable to price
CABLE	Four Core overall screened cable. Price per metre.
PINTOOL	Plug pin insertion tool.

Power Supplies

CLPP	Single curtain supply only. 240 Volts AC.
Transformer	Multi-tapped transformer. Up to 4 curtains. 110-250VAC
CLPUP	Regulated supply 85-265VAC. Up to 4 curtains.

Chem-Sealing kits

CL300SK	Chemical wash-down sealed enclosure to suit CL300A
CL450SK	Chemical wash-down sealed enclosure to suit CL450A
CL600SK	Chemical wash-down sealed enclosure to suit CL600A
CL900SK	Chemical wash-down sealed enclosure to suit CL900A
CL1200SK	Chemical wash-down sealed enclosure to suit CL1200A

SIGRA LIGHT CURTAINS
3.2 APPLICATION SHEET

CL SYSTEM APPLICATION SHEET. DATE ___/___/___

CUSTOMER: _____ YOUR O/N _____

INSTALLER _____

MACHINE TYPE OR FUNCTION: _____

SKETCH OF APPLICATION

MACHINE

COMMENTS

MACHINE PRIME MOVER. ELECTRIC HYDRAULIC PNEUMATIC

DISTANCE OF GUARD TO TRAPPING SPACE _____mm

CURTAIN 1 HEIGHT:	300	450	600	900	1200	1500	1800	OTHER	<input type="checkbox"/>	RANGE _____m
CURTAIN 2 HEIGHT:	300	450	600	900	1200	1500	1800	OTHER	<input type="checkbox"/>	_____m
CURTAIN 3 HEIGHT:	300	450	600	900	1200	1500	1800	OTHER	<input type="checkbox"/>	_____m
CURTAIN 4 HEIGHT:	300	450	600	900	1200	1500	1800	OTHER	<input type="checkbox"/>	_____m

CONTROLLER

PRE-WIRE OPTION: NIL 1 CURTAIN 2 CURTAIN 3 CURTAIN 4 CURTAIN

CABLE LENGTHS REQ'D		PLUG ONE END (PW05)		PLUG BOTH ENDS (PW10)	
QTY	LENGTH	QTY	LENGTH	QTY	LENGTH
_____x	_____m	_____x	_____m	_____x	_____m
_____x	_____m	_____x	_____m	_____x	_____m
_____x	_____m	_____x	_____m	_____x	_____m
_____x	_____m	_____x	_____m	_____x	_____m
_____x	_____m	_____x	_____m	_____x	_____m
_____x	_____m	_____x	_____m	_____x	_____m
_____x	_____m	_____x	_____m	_____x	_____m
_____x	_____m	_____x	_____m	_____x	_____m
_____x	_____m	_____x	_____m	_____x	_____m

AMBIENT LIGHT LEVEL: INDOORS OUTDOORS

ENVIRONMENTAL PROTECTION REQ'D. IP65 DIP CORROSIVE FLAME PROOF

ARC WELDING NEARBY YES NO

XENON BEACON NEARBY YES NO

FILLED IN BY _____ **SIGNATURE** _____

3.3 TERMS AND CONDITIONS OF SALE

SIGRA OPTRONIC PTY LTD and its Subsidiaries

1. Where hereinafter appearing, the words "the company" shall refer to Sigra Optronic Pty Ltd. and its subsidiaries.
2. Where hereinafter appearing, the words "the purchasers" shall refer to the person, persons or corporation named on the face of this document.
3. The following are the terms and conditions of sale for the goods specified on the face hereof unless the sale is pursuant to a written quotation from the company in which case the terms and conditions appearing on the quotation form shall prevail over these terms and conditions where the same are inconsistent.
4. Unless otherwise agreed in writing the company when giving any quotation or supplying any goods shall not be taken to have approved any specification as being suitable for any particular purpose and shall not be liable for any loss or expense whether consequential or otherwise or delay resulting from defects in or any unsuitability of the specification. The purchaser shall be responsible to the company for all costs to the company whatsoever arising from a change in the specification stated on the invoice.
5. The company will not be liable for delay in delivery or non-delivery (for any loss or expense associated therewith) which is attributable to transport delays, plant or equipment break downs, unavailability or shortage of materials, industrial stoppages or any other cause whatsoever which is beyond the direct or indirect control of the company.
6. The purchaser becomes bound by the information on this document including these terms and conditions of sale upon taking delivery of the goods or upon signing this document, whichever occurs first.
7. Any reference to the purchaser in these terms and conditions includes the employees, agents, sub-contractors, successors and assignees of and any entity claiming through or under, the purchaser. The action or signatures of any person appearing to the company to have the authority of the purchaser so to shall bind the purchaser.
8. All other guarantees, warranties or representations expressed or implied and whether arising by salute or otherwise are hereby expressly excluded (except to the extent only that such exclusion is prohibited by salute) and subject to the last mentioned exception these terms and conditions are the only terms and conditions of the contract between the company and the purchaser. These terms and conditions cannot be altered except in writing by the company's duly authorised representative.
9. The purchaser shall not, and shall not be entitled to claim against the company in connection with any act, omission or event arising hereunder, unless the claim is made to the company in writing within 7 days of delivery of the goods except where the claim is for non-delivery in which case such claim must be made in writing within 14 days from the date of the invoice. All claims made by the purchaser must refer to the invoice number and date of the invoice and state the reason for the claim.
10. The construction, validity and performance of any contract arising hereunder, shall be governed by the laws in force in the State of New South Wales.
11. Any description of goods contained in this contract is given by way of identification only and the use of such description shall not constitute this contract a sale by description.
12. a) The purchaser shall pay the price (being the amount referred to on the face of this invoice) to the company in cash within the credit period agreed to in writing between the company and the purchaser and if no agreement, forthwith upon delivery. All amounts not duly paid shall bear interest at the over-draft rate charged by the company's principal bankers in respect amounts over \$100,000 from invoice date until payment. All amounts received by the company will be credited first against the interest.
b) If the purchaser fails to make due payment the company shall have the right at it's option:
 - (i) to suspend further performance of it's obligations hereunder until payment of the monies unpaid (plus interest as aforesaid): and/or
 - (ii) to terminate the contract at anytimein either case without affecting any right or remedy of the company whether arising for, after, or as a result of the purchaser's failure to make a due payment.
13. The purchaser shall not be relieved of any obligation to accept or pay goods by reason of any delay in delivery or dispatch of the goods.
14. The company is not liable for any freight charges for return of goods for any reason whatsoever unless authorised in writing by the company and the company's nominated carrier is used.
15. Only stock catalogue lines of goods may be returned for credit at the discretion of the company and these goods may be subject to restocking charges at the company's discretion and may be accepted only if received in their original condition. Any goods which have been specially cut to length, made to order or treated in any way cannot be returned to the company for credit.
16. Acceptance of delivery of goods returned for credit does not oblige the company to issue a credit note in respect of those goods. A credit note will be issued only after the goods have been inspected and found to be satisfactory in the opinion of the company. In the event that the company decides that a credit note is not to be issued, the purchaser will be advised and the goods made available to the purchaser for collection by the purchaser.
17. The company will not be responsible for any delays in passing credit caused by the goods being incorrectly branded or returned to any destination other than the company's factory nor will the company be responsible for any delays if the company's nominated carrier is not used to return the goods.
18. The goods sold by the company to the purchaser are at the risk of the purchaser once the said goods leave the company's premises unless the company specifically agrees in writing otherwise with the purchaser.
19. The price listed in the company's catalogue or price lists are subject to change without notice being given to the purchaser. All prices are ex-factory unless otherwise agreed to in writing between the company and the purchaser. Sales Tax is not included in any price and if applicable is the responsibility of the purchaser.
20. The end use of the parts provided by the company to the purchaser and assemble or otherwise treated by the purchaser is beyond the control of the company and the company does not make any guarantees, warranties, undertakings or representations express or implied and whether arising by statute or otherwise (except to the extent only that such exclusion is prohibited by statute) with respect to the end product.
21. Title to the goods shall not pass to the purchaser until all monies owing by the purchaser to the supplier in respect of those goods have been paid and accordingly any sale of these goods by the purchaser to a third party will be made by the purchaser as agents for the supplier and the sale proceeds will be held in trust for the supplier as its property. Failure to comply with the provisions herein, the company may exercise its right to enter the property where any such goods are being held to remove the same.
22. Sigra Goods are not for Sale/Resale in USA or Canada

4 STANDARDS

4.1 AS4024.2(INT.) 1992

Withdrawn in 1995 but was still called up in the National Plant Safety regulations recognised in all states as the Australian Standard, until the release of A.S.4024.3 in 1998. Sigra Verified.

4.2 AS4024.1 1996 GENERAL PRINCIPLES

General principles of machine safety and guarding as well as risk assessment.

4.3 AS4024.2 1998. INSTALLATION AND COMMISSIONING REQUIREMENTS FOR ELECTRO-SENSITIVE SYSTEMS-OPTOELECTRONIC DEVICES.

Deals specifically with installation of Light Curtains. Gives details of safety distances (distance of light curtain from trapping space), and how to calculate them from curtain resolution, and total response time (light curtain response + machine stopping time).

4.4 AS4024.3 1998.

Deals with the design and performance of Light Curtains. Virtually identical to A.S.4024.2(int.) 1992.

4.5 AS4024 PARTS 4 & 5

Deals with design, performance and installation of Pressure Mats.

4.6 BS6491 PARTS 1 AND 2.

B.S.6491 British Light Curtain Standard. Treated as Equivalent to AS4024 Parts 2 and 3.

4.7 IEC61496 PARTS 1 AND 2.

IEC61496 International Safety Light Curtain Standard. Treated as equivalent to AS4024.

4.8 EN50100

EN50100 European Light Curtain Standard. Treated as equivalent to AS4024.

4.9 SIGRA APPROVALS

At The time of preparing this document, the CL system has been independently verified by the Work Cover Authority of New South Wales' Techsource Laboratories at Londonderry for compliance to A.S.4024.2 (INT 1992) and to B.S.6491.1 (1987). With the release of A.S.4024.3 (1998), Standards Australia issued an open letter, stating how the new standard differed from the 1992 interim standard. From this letter, we conclude that the only as yet unverified aspect of the CL system's performance, is it's ability to operate at 95% relative humidity. This verification is presently being sought.

5 MACHINE INTERFACING

5.1 ANTI-REPEAT.

If a light curtain on a machine is obstructed, the machine will stop. If the obstruction is removed from the curtain, the machine must not immediately re-start, unless you give it a signal to do so.

Like-wise, if you must hold down a foot-pedal for the machine to operate, the machine must not re-start, when the light curtain has been obstructed and cleared, until the pedal is released, then pressed again. These functions are called anti-repeat function, and this can be easily achieved with the reset terminals on the CL system controller.

5.2 VALVE MONITORING.

When a light curtain on a machine is obstructed, it stops the machine by removing power from whatever is causing the machine to move. For instance, if a pair of solenoid valves is being used to supply fluid to hydraulic cylinders, the curtain's output relays would de-energize the solenoid valves to close the flow to the cylinders to stop the dangerous motion. These sorts of valves have limit switches attached so that we can monitor whether the valve is open or closed. These switches can be connected into the CL system reset circuit and be monitored. If one of the valves does not close when called upon, the CL system will detect this failure and prevent the other valve from re-opening until the fault is rectified.

5.3 MUTING.

The mute function of a light curtain is used when it is necessary for an obstruction to be

ignored by the light curtain, for example, during the safe opening stroke of a press or guillotine. This would allow the operator to remove a finished workpiece from the machine before the machine had actually stopped. This allows faster, yet safe production.

5.4 APPLICATIONS IDEAS

Presses	Folders	Guillotines,
Robots	Palletiser	Depalletisers
Conveyors	Rollformers	Die-cutters
Slitters	Filter presses	Extruders
Pallet wrappers	Filling carousels	
Pressure mat-replacement		
Carton folders/gluers		

5.5 RISK ANALYSIS

This section is very important but fairly simple. An assessment basically determines what is the worst possible injury that a machine could inflict on the operator, how often the operator is exposed to this chance of injury, and the possibility of avoiding the injury. From this assessment we decide on the type, positioning, and category of guarding required, as well as the interface to the machine. For the specific details of how to perform a risk assessment, refer to **AS4024.1, 1996**.

6 ACCESSORIES

6.1 MIRRORS

Mirrors are used to bounce the curtain of light around corners, making it possible to guard two or three sides of a machine with a single curtain, see **Figure 4** in the operation manual **Section 2.6**. The use of mirrors can be very cost effective, however there are a number of drawbacks. Mirrors are more difficult to align than transceivers, so they require substantial mounting points otherwise they will need constant re-aligning. For this reason, it is strongly recommended that not more than two mirrors be used in a curtain without at least consulting Sigra. Mirrors also reduce the range of the curtain, by as much as 15% per mirror, and this attenuation is also increased by the distance.

6.2 CHEMICAL SEALING KITS

“Chem” seal kits are used predominantly for caustic wash-down areas as found in most food processing or bottling plants so that the corrosive chemicals used, do not make contact with the transceivers. The sealing kits should not be used around organic solvents.

6.3 HAZARDOUS AREAS.

EXP enclosures are used for flame proof or explosion proof capabilities are needed.

6.4 POWER SUPPLIES

The standard CLCBA controller requires 24Volts D.C. If this is not available, the CLPUP can provide a regulated supply for the light curtain with input voltages from 85-265 volts A.C. Not more than a single four curtain system should be supplied from a single CLPUP.

6.5 CABLES

Sigra can provide complete pre-wired plug and cable assemblies. Part number PW05, specifies a pre-wired plug assembly, after that mark the cable length in metres.

7 INDEX

A

Accessories, 3-2, 6-1
 Alignment, 2-6
 Alignment indicators, 2-6
 Ambient temperature, 2-17
 Anti-repeat, 5-1
 Application sheet, 3-1
 Application sheet, 3-3
 Applications ideas, 5-1
 Approvals, 4-1
 Arc suppressor, 2-8
 AS4024, 2-4, 4-1, 5-1

B

Brake press, 2-4
 BS6491, 2-8, 4-1
 By-pass, 2-4

C

Cable, 2-5
 Cable assemblies, 1-3
 Cable markings, 2-5
 Cable termination, 2-5
 Cables, 3-2, 6-1
 Chemical sealing kit, 2-17
 Chemical wash-down enclosures, 1-3
 Clearance, 2-4
 Colour coding, 2-5
 Compliance to Standards, 2-18
 Connection to machine control, 2-5
 Connection to machine control, 2-8
 Controller, 1-1, 2-3, 3-2
 Controller, 1-2
 Controller dimensions, 2-9
 Controller functions, 1-2
 Controller terminations, 2-5
 Controller wiring, 2-13
 Cross talk, 2-6
 Curtain heights, 2-17

D

DIP, 2-17
 Detailed inspection, 2-3
 Detection capability, 2-17
 Detection pattern, 2-3
 Drawings, 2-9
 Dust ignition proof, 1-3, 2-17

E

Earth, 2-5
 Electrical connection, 2-4

EN50100, 4-1
 Environmental protection, 2-17
 Explosion proof, 6-1

F

False curtain, 2-6
 Final switching devices, 2-8
 Flame proof, 6-1
 Flame proof housing, 2-17
 Flyback, 2-8
 Foot-pedal, 5-1
 FSD, 2-8

G

Green status light, 2-6
 Guard only, 2-4

H

High ambient light, 3-1

I

IEC61496, 4-1
 Inductive load, 2-8
 Installer, 2-3

L

Labeling, 2-5

M

Machine cycle, 2-4
 Machine interfacing, 5-1
 Machine primary control, 2-4
 Machine primary control elements, 2-8
 Machine stopping time, 2-4
 Mirror, 2-6
 Mirror, 2-17, 3-2, 6-1
 Mirror dimensions, 2-11
 Mirrors, 1-3
 Mirrors, 2-7
 Monitoring, 2-4
 Mounting, 2-4
 MPCE, 2-8
 Multiple curtain systems, 2-6
 Mute, 2-4, 5-1
 Mute, 1-3, 2-8

O

Operating mode, 2-4
Operation manual, 2-1
Ordering information, 3-1
Output, 2-8
Output relay, 2-7
Outputs, 2-17

P

Part numbers, 3-1
Periodic checks, 2-3
Pin carrier, 2-5
Pin insertion tool, 3-2
Pins, 2-5
Plug assembly, 2-5
Power requirements, 2-17
Power supplies, 6-1
Power supplies, 1-3, 3-2
Pulse, 2-4

R

Range, 3-2
Red alignment indicators, 2-6
Reflections, 2-6
Reset, 1-3, 2-6
Reset, 2-4
Resolution, 2-7
Resolution, 2-17
Response time, 2-17
Risk analysis, 5-1

S

Safe installation, 2-8
Safety, 2-3, 2-5
Safety net pattern, 2-3

Screening, 2-5
Sealing kit, 6-1
Sealing kits, 3-2
Separation distance, 2-4, 2-14
Single loop control, 2-8
Slave relay, 2-8
Soldering, 2-5
Specifications, 2-17
Standards, 4-1, 2-18
Standards, 2-3, 2-4
Statement of Compliance, 2-18
Stopping performance monitoring, 2-8
Strobe, 3-1
Sunlight, 3-1

T

Terms and conditions of sale, 3-4
Test piece, 2-3
Test piece, 2-7
Testing, 2-6
Testing, 2-7
The work cover authority, 4-1
Transceiver, 1-1, 2-3, 3-2
Transceiver dimensions, 2-10
Transceiver wiring, 2-12
Troubleshooting, 2-15

U

Unidirectional, 1-3

V

Valve monitoring, 5-1

W

Weld flash, 3-1